



Design Guide

This document will outline some design suggestions or factors that drive the costs of machined components. It will help the engineer make choices during the design process which may reduce the cost of the end product.

Choosing Materials:

When choosing materials, allow the use of different forms of the material such as bar stock and plate. There can be significant differences in the cost and lead time of acquiring different forms. The Table below shows approximate \$/lb and machinability ratings for common metals. Consider the strength vs. machinability rating as well when choosing materials. Choosing an annealed but heat treatable alloy of steel for example and then not specifying any heat treat will just drive cost with little benefit in material performance. As you see below, some aluminum can have even better performance than some grades of steel with significantly better machinability.

Alloy, Temper and Spec	Machinability Rating (1212 steel is 100%)	Ultimate Tensile / Yield Strength (ksi) typical	Price in \$/lb. (Feb 2009)
6061-T651 Extruded Bar - ASTM B221, AMS 4150, QQ-A-200/8	320%	45 / 40	\$1.60
6061-T651 Wrought Plate – ASTM B209, AMS 4027, QQ-A-250/11	320%	45 / 40	\$3.20
2024-T351 Extruded Bar – ASTM B221, QQ-A-200/3	380%	68 / 47	\$3.15
2024-T351 Wrought Plate – ASTM B209, AMS 4035, QQ-A-250/4	380%	68 / 47	\$3.95
7075-T651 Extruded Bar – AMS 4154, QQ-A-200/11	340%	83 / 73	\$3.35
7075-T651 Wrought Plate – QQ-A-250/12	340%	83 / 73	\$4.25
MIC-6 Cast Aluminum Plate – (Very Stable)	340%	24 / 20	\$3.25
304 Stainless Bar – ASTM A276, ASTM A479, AMS 5639, QQ-S-763	45%	90 / 40	\$1.45
303 UNS Stainless Bar – ASTM A314, ASTM A320, ASTM A582, AMS 5640	78%	90 / 35	\$1.89
416 Stainless Bar – ASTM A314, ASTM A582, AMS 5610	110%	75 / 40	\$1.65
17-4 PH Stainless Bar – ASTM A564 Type 630, AMS 5643	48%	150 / 110	\$2.25
1018 Steel CF Bar – ASTM A108	78%	67 / 45	\$1.10
A36 Steel HR Plate – ASTM A36	72%	(58-80) / 36	\$1.10
12L14 Steel Free Machining Steel Bar – ASTM A108	193%	78 / 70	\$0.80
4340 Alloy Steel Bar (annealed)– ASTM A322, ASTM A304	57%	110 / 66	\$1.40

Price can be significantly affected by the total weight being purchased and cut sizes, and these prices below assume a decent amount of material is being purchased.

Geometry Considerations - Radii:

One of the single biggest cost drivers for machined parts is the length of time it takes to machine it. The rigidity and strength of the actual cutting tools often determines how much time it takes. Very simply, the shorter a tool is, the faster it can feed, and the less the part will cost to make. The selection of these cutting tools is determined by the design of the part and a few simple rules can really help reduce machining time.

When designing parts that have pockets, or other features with vertical inside corners, you will need to leave a radius as the machining process uses rotating tools. Use the largest

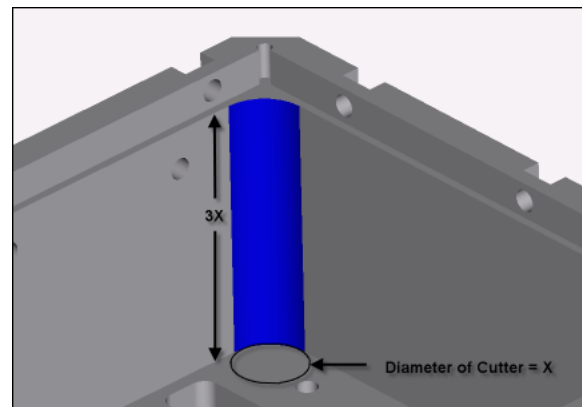

Fig. 1: Short and Rigid tool can cut this.

radii you can get away with. The tool that is used to machine a particular feature will obviously have a diameter of 2x the radius that you put in your model. If you design a part with a 1/8" radius, it will require a minimum of a 1/4" tool to cut that feature.

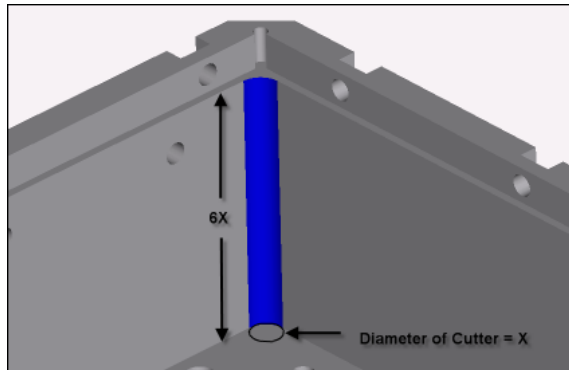

Fig. 2: Long and flexible tool needed.

Sometimes you just need to have a long small radius because of assembly issues. There are still options to reduce the cost of features like this. Figure 3 shows how you can make a virtually square corner with very little intrusion into the surrounding walls. This is a great technique if for weight or assembly reasons you can't tolerate a larger radius.

The key to this feature is to not put the center of the radius on the intersection of the inside edges. Put the center point inboard and then you can adjust it to fit your application. Use the biggest radius that fits the application as well.

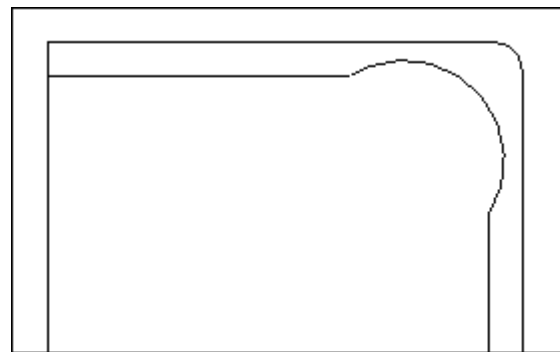

Fig. 3: Virtual sharp or small corner radius

It isn't uncommon for engineers to put a radius both on the floor and wall intersection as well as the vertical walls (see fig 4). With the "apply round" or fillet feature on most 3D CAD systems, the easiest thing to do is to select both that floor intersection and the wall intersections and just apply the same size radius to all those. But in fact, what saves you a few seconds work to have just one feature, can cause enormous headaches for the machine shop and cost you a lot of money in the long run.

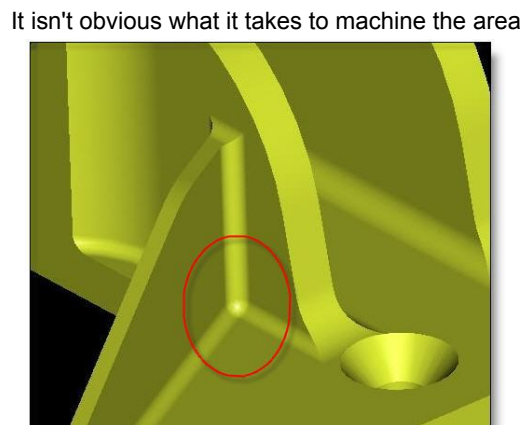

Fig. 4: Equal Radii on floor and wall costs 10X.

has radii on its tips. In the last issue of Pro Tips we identified that the larger the vertical corner radii can be, the faster the tool can travel and the cheaper the part will be. Generally speaking the smaller the

It isn't obvious what it takes to machine the area in the corner. It is much more complicated if the floor radius is smaller than the wall radius. Because of the equal wall and floor radii, two tools must be used to clean up this area completely. The wall needs to be cut with a ball end mill (an end mill with a full radius on the tip). The floor of the part needs to be cut with a flat end mill, but this will leave a triangular shaped section in the corner that neither tool can reach. (See fig 5).

This condition can be avoided by modeling the floor radii smaller than the wall radii (see Fig. 6). This enables the shop to machine this entire area with one tool that has a flat bottom but also

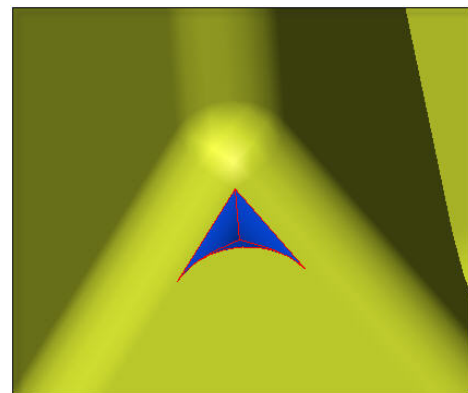

Fig. 5: Material in blue is hard to remove.



floor radii can be, the better, with a 0 radius being the easiest of all. In the US, tools are readily available with tip radii in .01" increments up to .125". And when indicating a tolerance of this floor radius on your drawing, make it as generous as possible to allow the shop greater flexibility in choosing tools.

To put it into perspective, the equal corner radii detail will easily cost 10x what the unequal corner radii detail costs. That should offer enough incentive to spend a couple extra minutes modeling the optimum radii on your part, and reap the benefits for the life of the part.

Material Shape and size:

The size and shape of your part is nearly always driven by the function. Sometimes the constraints are hard and fast but other times you have some flexibility to design the outer size and shape. There is a good opportunity to design out some cost by considering what size material the part might be made from. We already saw above in the material table, that if available, bar stock is always cheaper than plate material. When bar stock is chosen as on material option, it is best to consider what size stock your part might fit into.

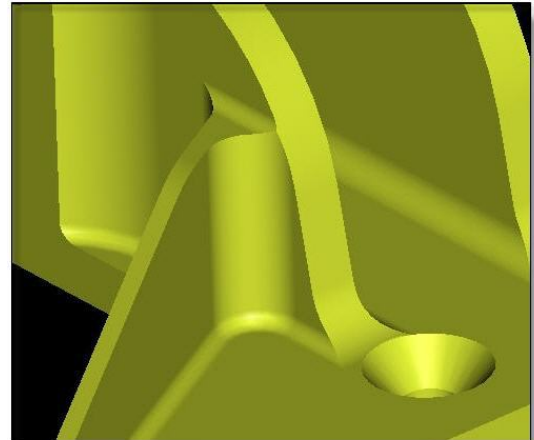

Fig. 6: A larger wall than floor radius is much faster to machine.

In Fig. 7 we see a part that is .74" thick x 3.3" wide. This part fits nicely into bar stock that is 3.5" wide, but it isn't quite thin enough to be made from .75" material. With only .01" clearance between the part and material we can't guarantee the tolerances and clean up the faces. In this case, we have to use 1" thick material which costs 25% more and spend time to remove extra material as well.

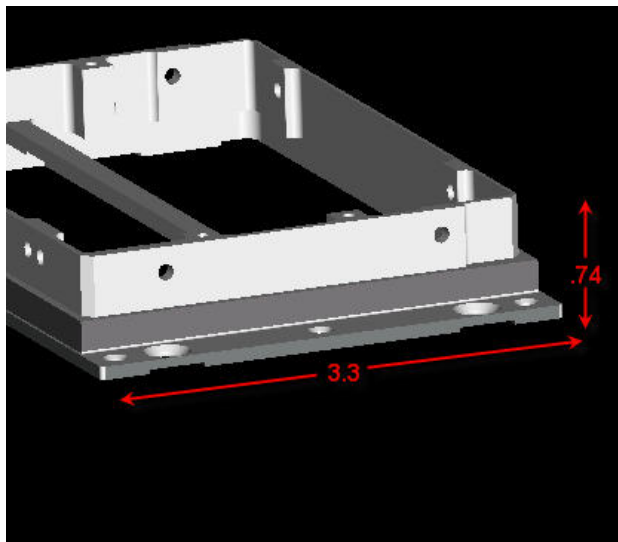

Fig. 7: This part could be cheaper if it were a little thinner.

shop early on for advice on where they will need to hold onto the raw material, and how much of it they will need when they machine it.

If the part could have been designed at a maximum thickness of .65" or less, it is likely that .75" material could have been used. There are some creative methods of minimizing excess material. For smaller parts that get clamped in a vice, .05" is probably about the minimum amount of excess that is needed. For very large flat parts that are held down with fixtures, occasionally even less can be left. If you are unsure, consult your manufacturer early on in the design phase where changes cost the least amount of money.

Occasionally, designing a part to be exactly the size of the raw material can be done if the tolerances and cosmetic requirements are very low and "stock" surface and tolerances are expected. If you need to have all sides finish-machined, a safe rule of thumb is to leave approximately .1" on the length and width and at least .125" on the thickness. The side the thickness would be measured along would be the one where the primary material removal is occurring. With some designs, it isn't clear which way the part would be machined and it is prudent to engage the machine

Tolerances

Nothing can drive up costs on a part more quickly than tight tolerances that are difficult to machine or measure. Some tight tolerances are not any problem at all to achieve, while others are very challenging. All too often we see drawings with poorly applied tolerances which drive up the cost of the part or worse, potentially not fitting together with its mating parts. A better understanding of the machining process will allow the engineer to specify an intelligent tolerancing scheme which serves their needs well but doesn't needlessly drive up costs.



As a rule of thumb, features that are created by the machine tool capability will be relatively easy to hold to a high tolerance. On the other hand, features that are affected by operator handling and loading into subsequent fixtures will be much harder to hold at a high tolerance. An obvious example of an easy to hold tolerance is the dimension between two steps on the same side of a part as seen in Figure 8. The same tool will be used on these faces and the positional accuracy of the CNC machine will be the primary contributor to variability (essentially zero). With a positional accuracy of around .0001" [.0025mm] on an average CNC machine, this should be much tighter than most applications require. So if you need to specify a tolerance of .002" [.05mm] this shouldn't pose too much of a problem. Conversely, if you need to specify a high tolerance to the opposite face of the part, like in Figure 9, this would be much more challenging. The reason for this is because in most cases the part will be removed from the CNC machine, manually flipped upside down and re-clamped in order for the back side to be machined. There are a lot of variables introduced with this process and a tolerance of .002" [.05mm] would be much harder to achieve. There would likely be more complicated fixturing, longer machine set-up, longer loading times per part, and a higher scrap rate. These would all drive cost considerably.

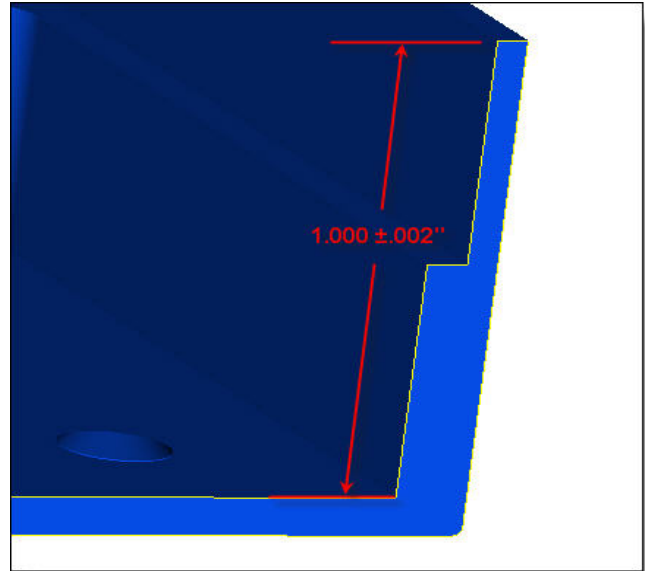

Fig. 8: Faces on the same side are easier to hold tightly.

Given the above, parts will still generally be less expensive to make when tolerances are looser. Often engineers rely on the tolerance block to help communicate their needs such as .xx = .01", .xxx = .005", .xxxx = .001" (or metric equivalent). Sticking with these general tolerances is easy to specify but may drive cost needlessly. If .005" is too loose of a tolerance, it doesn't mean that .001" is the only other option. Why not specify something in the middle, such as .003" or even .0035"? An intermediate tolerance may be much easier to achieve and subsequently less expensive. When working with smaller tolerances, a small difference can be vastly easier - .0015" is 50% more tolerance to work with than .001". Depending on the application, that extra .0005" might make the difference between hitting your parts cost budget or not.

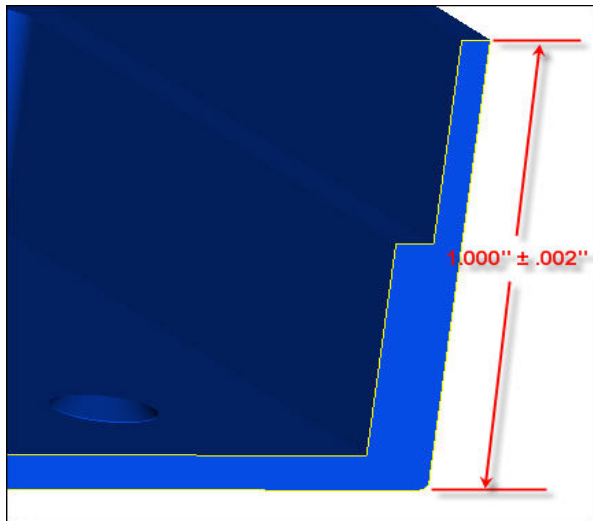

Fig. 9: Faces on opposite sides are more difficult to hold tightly.

With every application there is a point of diminishing returns where loosening up the tolerance won't lower the cost of the part. If the process employed to make the feature can easily hold the tolerance, then making it looser will not reduce price, unless it becomes loose enough that a different and less expensive process can be used. For example, a part's tolerances could be loosened enough that it becomes feasible to use profiling technology like laser cutting, abrasive waterjet, or routing. You may also consider the option of supplying a mating part for an in-process fit check. It may also be sufficient to perform a "program check" where the programmer verifies that the feature will match the model but there is no physical verification done. Discussing specific applications with your manufacturer is the best way to determine if changes might apply in your application.

It is becoming common to apply a global profile tolerance to an entire part. While easy to specify, this may require significant inspection costs to prove. Even if a part does fall inside a profile tolerance, the manufacturer would need proof of that being the case. This would require a

significant number of hand measurements or a full CMM report, either of which is costly. While profile tolerances have a real purpose, be sure you are using them effectively.

Threaded Holes

Threaded holes can vary widely in cost. One thing to keep in mind is that depths of threaded holes are harder to control and costs can increase quickly for threaded holes with tight depth tolerances. The reasons behind the high costs are very low first part yield and requalifying a replacement tap and subsequent scrappage. The most common mistake is to leave a threaded hole depth dimension with 3 decimal places so it defaults to the title block tolerance (typically +/- .005"). The reason this is a problem is that taps are not very consistent between their tip and the first full thread. A "bottoming" tap typically has between 1.5 to 2.5 leading threads before the thread profile is complete. We can measure the tap and try to approximate the amount of lead for any specific tap but it is much easier to specify a looser depth tolerance. There aren't many circumstances where the threaded hole needs to be held tightly. One circumstance this tolerance might need to be high is if you have a blind threaded hole where you need a minimum of threads but it can't break out through the other side of your part. In these cases, we are generally faced with also having a very short distance between the bottom of the pre drilled hole and the bottom of the threads. Again here, the limiting factor on the distance between the full thread and the bottom of the hole is the tap itself.

In figure 10 we see an example of a hole where the minimum distance from the shoulder of the drill to the first full thread is illustrated. In this case, a 1/4"-20 hole would need a minimum of .125" (.05" pitch x 2.5 threads). Any greater than that will not save money but any tighter than that will take more adjusting and cost more.

We also see in yellow text the most cost effective way to notate this thread on the drawing. The depth is called out as .88 min rather than .875. We also see that there is no pre-drill size specified. Cut and roll taps use different sized predrilled holes so the predrill size should not be specified unless there is a very specific reason for doing so. The chamfer diameter in this example is also just two decimal places which is much less expensive than using three decimal places. To give an example of how costs can be affected by these tiny details, if this hole callout specified a predrill size, a .875 depth, a .270 chamfer and had less than .125" clearance to the drill shoulder, this hole could easily cost 3x - 5X what it does as represented in yellow text.

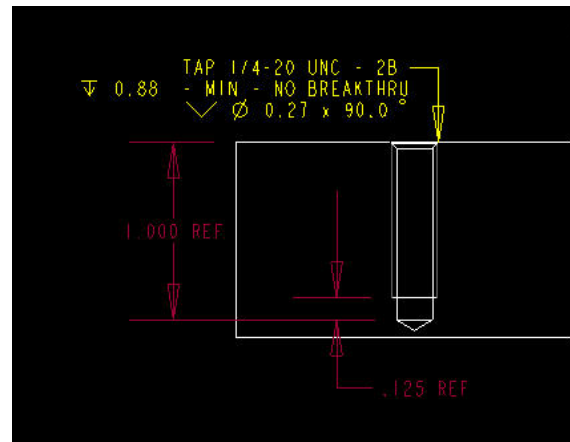

Fig. 10: How much clearance to leave and the cheapest way to specify the hole dimensions.

Here are a few other notes about best practices or cost drivers for threaded holes. It is advisable to avoid 6-32 threads; the ratio of major to minor diameter is greater than other thread sizes which makes the tap more likely to break than other sizes. Also, don't specify threaded holes that are deeper than you need. They become expensive as taps are more likely to break the deeper you go. If the thread depth is greater than your fastener will thread, the result is wasted money. If you do have a deep thread that is through the part, make sure you specify if all the threads need to be from one side or if tapping from both sides is acceptable. A shop might assume they can tap from both sides, in which case the threads will not be contiguous which may or may not work with your design.

As mentioned above, threads such as in this example can be made with cutting taps, roll forming taps, or thread-milled. If executed well, formed threads are stronger than cut threads and the taps generally are stronger and last longer so they are less expensive to create. Formed threads have their own unique challenges for the shop though. If the minor diameter is not held extremely close then the threadform may not be perfect leading to issues with installing threaded inserts. Roll forming does not create chips down in the bottom of the hole which is an advantage. Some materials do not lend themselves to being formed though. Really hard and soft materials will generally be cut threaded and medium hardness materials like aluminum and softer steels respond well to roll forming. Generally though, leaving the option up to the manufacturer is advisable unless your situation specifically precludes an option.

Sometimes you need threads that are stronger or more durable than your base material can offer. In these cases a threaded insert is a good option. With plastics, the only realistic option is a heat staked or ultrasonic staked insert such as a PEM insert. They are inexpensive and easy to install. With metals, there are more choices. STI (Helicoil) inserts, Keenserts, and solid female threaded PEM inserts are all options. Generally speaking, Helicoils are less expensive to buy, install and service later. In our experience, engineers often specify threaded inserts but after discussing their needs threaded inserts are unnecessary. If you can engage your fastener at least two times its diameter in threads, then even in aluminum there's a good chance the threads will be stronger than the fastener

PRO CNC INC	445 SEQUOIA DRIVE / SUITE 113 / BELLINGHAM / WA / 98226	
--------------------	---	---

itself. Depending on the application, it may be cheaper in the long run to occasionally repair a thread than to specify them all as inserts. We estimate that a typical Helicoil costs approximately an additional \$1 - \$3 to buy and install compared to a plain threaded hole. The bottom line is to really consider if you need that insert and try to transcend the argument that you need to include inserts because it's the way your company has always done it.

Anodizing and Chemical Conversion Coating

Chemical Conversion Coating

In reference to coating aluminum, this process is known by many common names - chem film, Iridite, Alodine, conversion coat or chromate. Chemical films are gelatinous films used to provide corrosion protection to aluminum alloys. The coating also improves adhesion of subsequent coatings such as paint and powdercoat. They are typically either clear/colorless or gold and yellow with a tint of brown. It is important to note that different material alloys may appear different in color when processed identically. It is not generally considered a cosmetic process as color can vary. The distinction between clear and colored may be specified on the drawing, but colored will be used by default. Chem film is a cost effective substitute for anodizing when abrasion resistance is not needed; it also has the benefit of maintaining electrical conductivity which anodizing will not.

The military specification (also used commercially) for this plating process is [MIL-DTL-5541F](#). MIL-DTL was introduced in 2006 and superseded MIL-C-5541E which was the standard for many years. Although MIL-C is obsolete, it is still commonly specified on drawings today (Yes, I'm talking to you). There are two classes, 1A and 3. Class 1A is thicker and provides maximum corrosion protection but has greater electrical resistance; it is generally darker in color. Class 3 is thinner, providing less corrosion protection but has better electrical conductivity. The new MIL-DTL spec has introduced Types I and II. Type I contains hexavalent chromium which was the only option in the now obsolete MIL-C spec. Type II contains no hexavalent chromium which makes it compliant to [RoHS](#), the restriction on certain hazardous substances. More plating companies are now offering Type II but it is not yet ubiquitous in the industry. If no type is specified on the drawing, then Type I is the default. Similarly, if the coating class is not specified, then Class 1A is recommended. An advantage to this coating type compared to anodizing is that it can be repaired with an approved touch-up method. Per the MIL spec, up to 5% of the surface may be touched up unless the contract states it can be more or less. Unless your application has zero margin for error, it is prudent to allow the use of a touch-up method because chem film is relatively easy to scratch, especially if there are assembly processes after plating. The touch up methods still provide a very good level of protection.

Chem film does not add any measurable thickness so in most applications provisions for plating thickness do not need to be taken into account at the design or machining stages. The pricing for chem film is significantly cheaper than anodize on a per-part basis - typically about 60% less, but minimum lot charges will apply and generally vary from \$60 to \$120.

Anodizing

[Anodizing](#) is an electrolytic process which converts the outer surface of metals to an oxide layer, protecting the underlying metal from corrosion. It is most commonly used on aluminum but can be used on some other non-ferrous metals. The two most common types controlled by MIL-A-8625A, are Type II and Type III. Both types are called sulfuric anodizing with the thickness being the primary differences.

Type II is considered cosmetic anodize and can vary in thickness from .00007 to .001" (1.8 µm to 25 µm) with .0003" being an average (+-.0002" tolerance). It can be clear (Class 1) or colored (Class 2). If you specify Class 2 you must specify a color as well. There are a wide range of colors available with Type II Class 2 although getting close matches can be very difficult. If precise color is important, it is best controlled with boundary samples. The subjectivity of the color can often be a very challenging aspect of anodizing and can lead to significant costs and delays. Different alloys will color differently which should be considered if you have a cosmetic assembly with machined and sheetmetal parts made from different alloys for example.

Type III is also called hard anodizing. It is much thicker than Type II varying in thickness from 0.001" to 0.006" (25 and 150 µm). If a thickness is not specified then the nominal thickness is to be .002". Hard anodizing penetrates the substrate as much as it builds up and thickness includes both the buildup and the penetration. Type III hard anodizing offers significant wear resistance, scratch resistance and thermal and electrical resistance compared to cosmetic Type II. When maximum abrasion or wear resistance is needed, a final sealing step should not be used. For maximum corrosion protection a sealing process is used, and the type of sealing should be left to the plating company unless you have a specific requirement for sealing. It is interesting to note that abrasion resistance does not improve with additional thickness and will decrease above .0025". The same color classes are used with Type III (Class 1 for clear or Class 2 for colored). Hard anodizing is not considered a cosmetic grade and most plating

companies will not guarantee the color results as they will with Type II. It is possible for hard anodize to look fairly nice but it is not going to be consistently so. One additional note is that Type III "clear" is really not clear at all, and is often dark grey with shades of green.

It is prudent to specify where you would prefer to have racking marks. These marks are unavoidable and can damage close tolerance features.

There is also a Type I (and variants IB and IC) anodize called chromic anodize. It is far less common but is good for use on fatigue critical components as it is the thinnest type of anodize. It is important to note that Type II and III may significantly reduce fatigue properties, and the thicker the coating, the greater the reduction will be.

Because of the thickness associated with anodizing, care must be taken to ensure the finished part functions as needed. There are a few ways to approach this: 1) Machining features accordingly to accommodate the plating thickness expected, 2) asking for zero growth of the after-plating dimensions, or 3) masking critical areas before plating. Specifying before and after dimensions is fairly straightforward in most cases. It requires a bit more detailing on the drawing, but can take the guess work out of the process. If the tolerance range of the anodizing is tighter than the finished machined dimension needs to be then this approach can be successfully used. But if the finished part needs to have higher tolerances then masking would be better. As an example, if you have a 0.500" hole with tolerance $\pm .0005$ " after plating, and the thickness tolerance for Type II is $\pm .0002$ " (which would apply to both sides of the hole), then the variability of the after-plating hole diameter would be $\pm .0004$ ". This would leave only .0001" of tolerance for the machinist which is not really practical (read: economical). Plugging the hole is the best option unless the surface must be plated. Asking for zero-growth can also work in many cases. The plater can acid etch the parts longer before anodizing to remove material so the buildup of plating has the minimum affect on overall size but this can come at the cost of surface finish. Threads can be particularly troublesome, especially with Type III anodizing. Because the plating thickness builds up on both sides of the hole and both angles of the thread helix, the reduction in pitch diameter is close to 4x the plating thickness. Oversized taps can be used but the thickness tolerance can make it nearly impossible to achieve a thread class. If the application can tolerate no plating on the threads, then plugging them before anodize is the best option. Plugging holes and threads is relatively inexpensive while masking broad surfaces adds considerable expense, lead time, and the chance for non-conformances.

We have seen applications where a part requires both anodize and chem film on different surfaces. If you don't ever have a need for this, count yourself lucky. This is a pretty expensive and trouble-prone option but can be successfully executed. There are two basic options to achieve this requirement: partial machining - anodizing - more machining - chem film or: machining complete - first plating process -masking - second plating process. The complexity and shape of the area with the different finish will help determine which of these applications is used. The former has advantages of no masking cost and the delineation between the plating types will be very clean and crisp. The

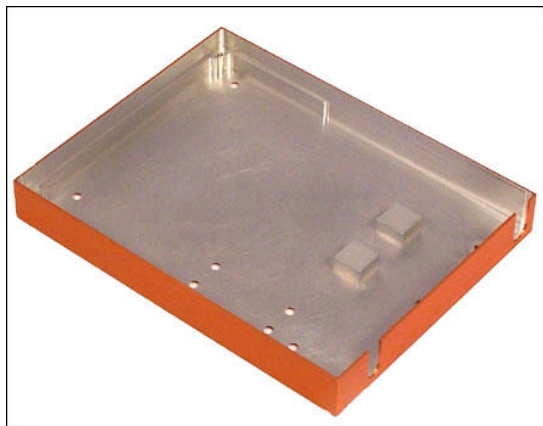

disadvantage is longer lead time, shipping costs and an additional machine set-up. An example of such a part is seen in Fig. 11. The entire outside of the part needs to be anodized for cosmetics while the inside needs to be conductive and have corrosion protection. An anodized surface will not be affected by submersion in the chem film process which is the key to allowing these processes to be used. If the area required to have chem film is relatively small and simple in shape (such as a flat grounding surface around a hole) then the most cost effective method is to mask the area, anodize the part and then chem film once the masking is removed. If your application does not require compliance to the MIL spec, then it is possible to get fairly good protection with a chem film touch up method only.

Fig. 11: This part required anodize and chem film. Two stage machining was used.

It is possible to install stainless steel hardware before chem film plating but not before anodizing. Depending on the application, this may not be advisable because chemicals may be trapped between the hardware and the part and leach out at a later time. If you are concerned about this, you should specify that hardware be installed after plating. In our experience with hardware such as Helicoil inserts, we have yet to see residue or leaching after the fact related to the hardware. Installing the inserts during the machining process rather than as a batch operation after plating, can save significant costs and lead time.

If you have a requirement for plating on certain surfaces, or even paint with masking, the clearest way to communicate it is with colored isometric views on the drawing. Most 3D CAD systems days can generate shaded full-color views on the drawing. Put a front and back view on the drawing showing which areas to mask. See Fig. 12. This even works well with different levels of cosmetic requirements in different areas, such as Class A (highly cosmetic) on the front face and Class C (seldom seen) on the back.

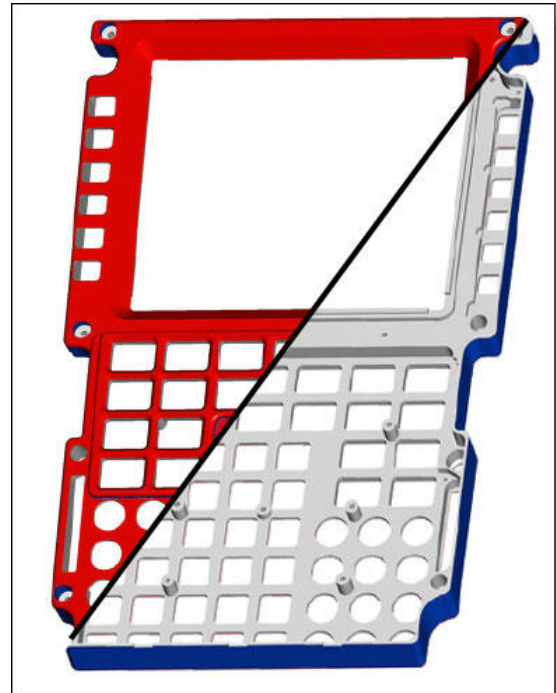

Fig. 12: Indicate masking or different surface conditions with shaded views on your drawing. Front and back surfaces shown.

Undercuts

Sometimes it is impossible to avoid creating a feature that can't be made with a standard end-mill; often this means using an undercut feature. See Fig. 13 for an example. These features are generally more expensive because they require a custom ground tool (see Fig. 14) in most cases and the cutting feeds are slower to accommodate the more fragile neck (N) diameter. Both the speed of the cutter and also the determination of whether or not the cut can even be made is based on the ratio of the cutting diameter (D) and height of cut (H) vs. the neck diameter (N) and neck

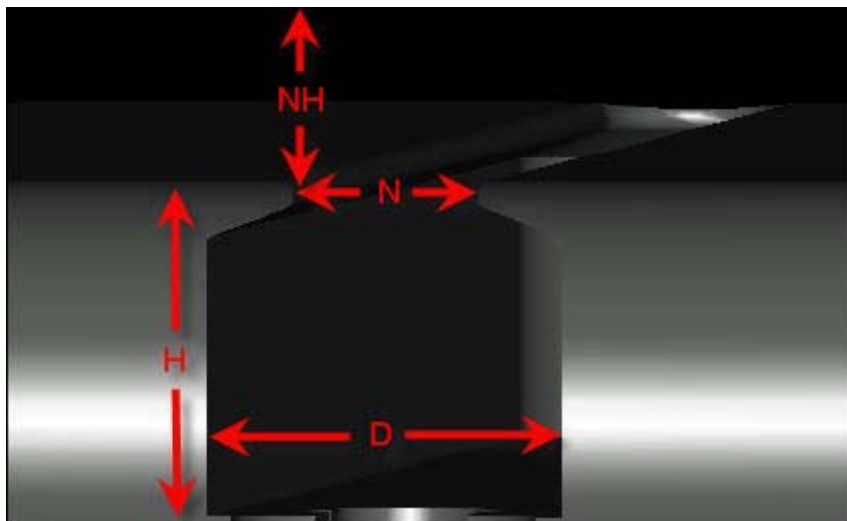

Fig. 13: This image shows a feature that must be machined with an undercutting T-Slot tool.

height (NH). There are no hard and fast rules about what ratio of D:N is possible, let alone one that will be inexpensive to produce. Because the length of the neck (NH) is also a critical factor, as is the cut height (H), a review of the D:N ratio is insufficient in calculating difficulty and cost. When any one factor, or a combination of factors, becomes too extreme the cutter would be so fragile that the risk of breakage at any reasonable feedrate would be extremely high.

It isn't uncommon to see an engineer specify an undercut feature that is not possible to make. The design of the

undercut is such that there could be no neck diameter or it would be so small as to be impossible. There is a pretty simple way to avoid this situation. If you are modeling a feature that requires an undercut, you can sketch in both the cutting and the neck diameters as shown in Fig. 14.

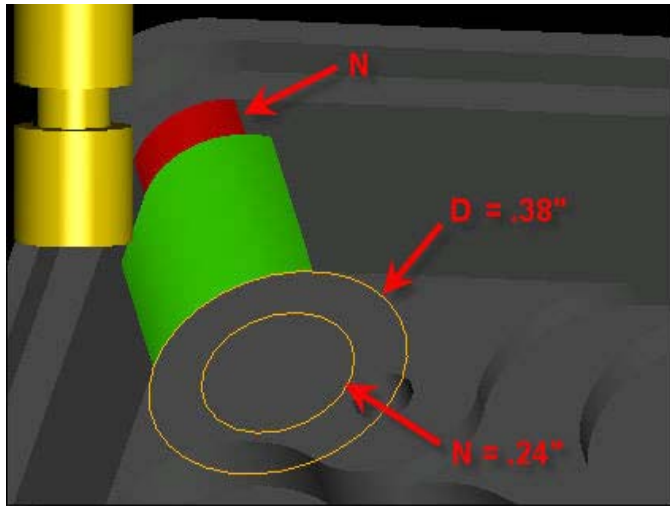

Fig. 14: This part has a well designed undercut.

tool with a 3.8:1 ratio; the tool needed would be very fragile and must be fed very slowly as the chance for breakage is very high. You may have a difficult time finding a machine shop willing to take this on or worse end up with parts that don't meet your requirements because of an interference from the omission of the tricky undercut. At best, you will pay a great deal for undercuts that border on impossible.

By following these steps and being aware of what type of cutting tool will be needed to machine your part, you can reduce costs and frustration levels often associated with these types of features.

Figure 14. We can see in this example, that the ratio of D:N is about 1.5:1 which is a very reasonable and inexpensive feature. You should also note the ratio between the cut height H and neck height NH are also at a reasonable ratio. The neck height is very short so the cutter will not be too fragile. (This part had much worse ratios before the customer consulted with Pro CNC). When you do this with your own part, measure and take note of these ratios to see if they seem too extreme and therefore expensive. It is also important to note that these two diameters share a common axis. That is not often the case and makes this exercise even more important in determining what the size of the cutting tool will be.

Figure 15 shows a poorly designed undercut and the corresponding tool that would need to be used to make the part. This design would require a

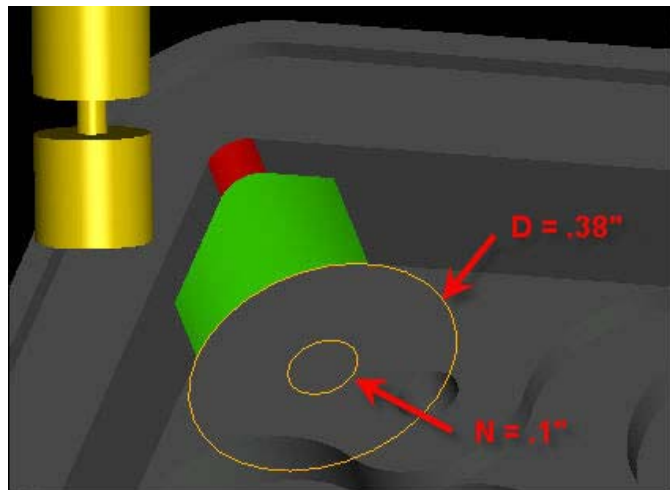

Fig. 15: This part has a poorly designed undercut.

Total Surface Profile

The use of GD&T has increased significantly over the last several years. Engineers are being trained to use it and becoming more familiar with it. It can be a great way to specify what tolerances and features are important to your design. There is also a trend in the industry to adopt minimally dimensioned drawings and rely on the 3D model to control feature shape and location. Unfortunately, these two trends can be at odds and can add unnecessary expense to making and inspecting a part. There is no faster way to add expense than with a misused profile callout. We will explain how best to use this powerful tool.

For companies that are ISO-9001 or AS9100 certified - or really any company with a comprehensive quality system - if a customer specifies a quality requirement, then the manufacturer must guarantee that the requirements have been met. This is the crux of the problem with a profile callout; it adds a requirement for all surfaces specified to be guaranteed to the profile tolerance. Typically, only a few surfaces are very critical to the function of a part and the rest

are much less important. If you are creating a minimally dimensioned drawing, you want the less significant surfaces to be controlled by the model. This process describes the intended purpose of a minimally dimensioned print; you will spend less time making your drawing when compared to a fully dimensioned drawing and it should take the manufacturer less time to inspect the drawing which directly reduces part cost. However, if you dimension the few items you care about and then specify a callout like the one in Figure 16 what you have actually done is increase the inspection requirement by an order of magnitude.

There are very few cases where this requirement is needed. By specifying all undimensioned features you are specifying every radius, every chamfer, every hole diameter - truly every surface on the entire part. Ensuring that all those features are

Undimensioned features are to be controlled by the model within a total surface profile tolerance of .005"

Fig. 16: Bad use of a global total surface profile callout.

within 0.005" is very expensive to manufacture and measure. It is reasonable to think that with modern CNC machines and CAM programs this requirement would be easy to meet, but it is not. While it is true that the part will be programmed from the 3D model and modern CNC machines are very accurate there are always obstacles to perfection. Even if the entire part is manufactured within 0.005", the work is only half done. The rest of it is proving the manufacturing, either with hours of manual measurement or hours spent programming a CMM to check the part.

The key to solving this problem is to not use a numerical value with your callout (for example, see Figure 17). It is the numerical value - no matter what the value is - that is the cost driver. Even if you specified that all undimensioned features only needed to be within 0.05", it still needs to be proven. The reality is that the part will be programmed to the 3D model, and that the part will be very close to the modeled and programmed size; probably well within 0.005" in many cases. If that assurance isn't good enough for any given feature, then you should specify a specific tolerance for that feature. And if you cannot trust your manufacturer to remain accurate and precise without a numerical value, then you probably need a new manufacturer.

Undimensioned features are to be controlled by the model.

As mentioned above, when you truly do need to control the profile of a given feature, then make sure you use a profile callout such as:

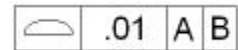
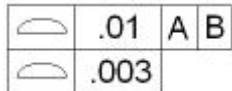

Fig. 17: Good use of how to control undimensioned features.

This type of GD&T not only controls the profile of the feature, but with the addition of the datums it also controls the location of the feature to the same tolerance. The addition of the datums can be appropriate if needed, but can also drive cost. Particularly with large and flexible parts, you may consider adding a note about checking the profile in a restrained condition. This may make the inspection significantly easier than in a free state. An alternate method for controlling the profile shape of a feature but allowing more leeway on location is with a compound profile callout such as:



This will allow .010" locational tolerance to the datums but only .003 on the shape of the feature.

We hope this issue has given you some good suggestions on how to keep the cost of making and inspecting your parts to a minimum. Few companies these days can afford to add cost to their product without adding value.

Bilateral vs. Unilateral Tolerances

Bilateral tolerancing (also known as symmetric tolerancing) is a method of tolerancing a dimension using equal plus and minus deviations from the nominal dimension. Unilateral tolerances (also known as asymmetric tolerances) on the other hand specify a deviation in only one direction, either plus or minus, from the specified nominal dimension. Unilateral tolerances may also take the form of plus and plus-plus, minus and minus-minus, or plus or minus some amount and plus or minus a lesser amount.

In the old days of hand cranked mills and lathes, it was quite easy for the machinist to decide on what dimension to arrive at while machining a part. If a customer specified a dimension with a unilateral tolerance such as: 2.500" +



0.000/ - 0.010" the machinist would either shoot for 2.495" (the safest place to be - in the middle of the tolerance range) or if he was a nice guy would shoot for 2.499" in an attempt to get as close to the dimension the engineer specified. There was more risk in being close to the limit but with a good machine and a skilled machinist the level of risk was low. I'm sure you are thinking at this point that with modern CNC machines it should be even easier to achieve whatever dimension the engineer desires. In some regards this is true. We can "comp" (use cutter compensation) a CNC machine 0.0005" one way or the other and it will do it handily. But the real difficulty with unilateral tolerances lies in the programming of the part. Nearly all CNC machines these days are programmed from a 3D CAD model using CAM software. The programmer chooses edges or surfaces on the model to drive toolpaths. Figure 18 shows a basic rectangle with one side having a bilateral tolerance and the other having a unilateral tolerance.

This is a pretty common example. In this case, the easiest way to program and manufacture this part is with a profile cut from the top of the part which establishes both the 4.000" and 2.500" dimensions at the same time with the same cutter. The CNC program by default will drive the tool at the nominal size of the CAD model. It will create a rectangle that is 4.000" x 2.500". But the sides with a 2.500" dimension will be practically out of tolerance as programmed since we cannot be on the plus side of nominal at all. And with the typical small amount of cutter deflection outward, the 2.500" dimension will likely be out of tolerance. This makes the programming of the part take much longer as the programmer will have to compensate for this with manual adjustments to the program, adjustments to CAM parameters or a separate program with tool paths for each side. The set-up of the part on the CNC machine may also take longer if the machinist needs to apply cutter compensation in order to bring the part closer to the middle of the tolerance zone. In an extreme example, if you had a tolerance of + 0.005"/ - 0.000" on the 4.000" dimension, it would be virtually impossible for either dimension to be in spec without major tweaking to the program. This brings up the other point about unilateral tolerances. Most CNC shops want to run the dimensions in the safest range to minimize the chance of scrap. So in the case of the part in Fig. 18, they would likely try to run the 2.500" dimension at 2.4975" which is exactly in the middle of the + 0.000"/ - 0.005" range. This somewhat defeats the purpose of specifying a unilateral tolerance in the first place. It would be easier for everyone involved if the engineer put a symmetric bilateral tolerance at 2.500" or 2.497" because more than likely it is what will be delivered anyway.

The issue of unilateral tolerances is not as much of an issue with holes (see Figure 19). Very often it is more critical to be able to hold odd tolerances on holes to achieve proper slip, or press fits, etc. Because most holes are machined with drills or reamers the same problem with programming does not exist. The size of the hole will be established with the tool, not the program. So if you need a .2500" hole for a press fit for a 1/4" pin then the shop

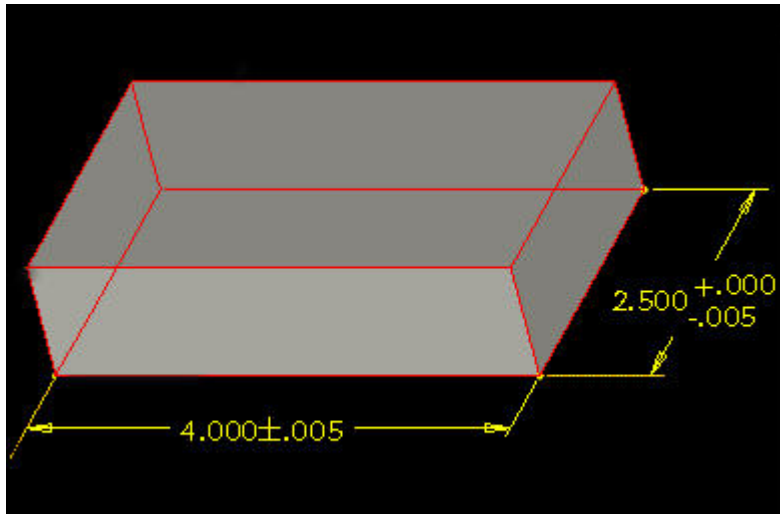

Fig. 18: Part with both unilateral and bilateral tolerances.

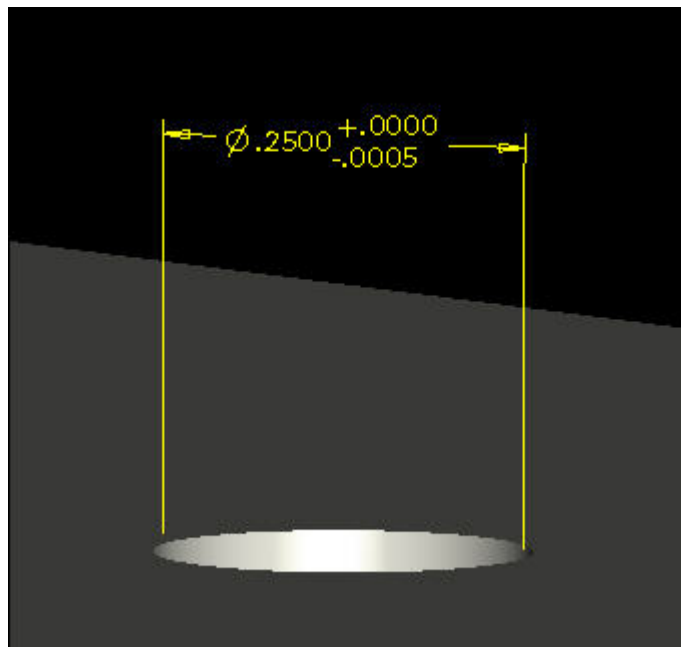

Fig. 19: Unilateral tolerances on holes are not a problem.

will select the exact size reamer needed. In the case of an odd sized hole that doesn't match a common drill size or reamer size, the problem may exist to a small degree. A hole such as that can be programmed with a circular interpolation using a smaller endmill to create a larger hole. Since that is more of a "stand alone" type of feature, the parameters can be more easily tweaked to achieve the desired tolerance without affecting other features on the part.

Armed with a bit of knowledge about which tolerance scheme is easier to machine the engineer can achieve their desired design objectives without adding cost to the product... an idea that we can all unilaterally agree is a good idea.

Countersinks and Chamfers

Any machined part that has holes in it probably also has countersinks. Countersinks are used as a lead-in for threads, for flathead screws, and just as a general edge break or chamfer on any type of hole where a lead-in is necessary. In many cases, the diameter of a countersink is not very critical and can often be dimensioned at a lower tolerance than the standard tolerances for the part. Unfortunately, we see all too often that the diameter tolerance is left as a 3 decimal place dimension which would assign a higher tolerance than is needed - generally $\pm .005"$. See

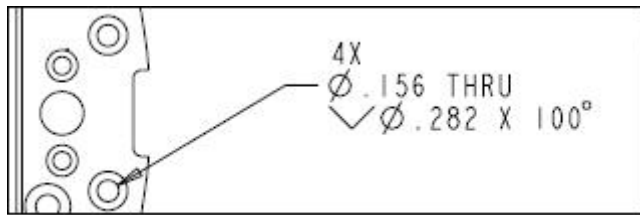

Fig. 20: Expensive countersink callout.

Figure 20. Normally that much tolerance is no problem for CNC machining. So why would this drive additional cost vs. a lower tolerance feature? There are a few reasons why this is a special case. Generally a countersink feature is specified as the diameter of the outer edge and the included angle. This feature is machined with a countersink tool and the Z-depth of the tool will determine how large the countersink is. If you recall back to your days of high school trigonometry, with a 90° included angle on the tip of the tool, for every $.001"$ change in Z-depth the diameter will change by $.002"$. See Figure 21. With a 100° or 120° tool the condition is further exacerbated - $.001"$ of movement with a 120° tool equates into $.0034"$ change in diameter. So to hold $\pm .005"$ on diameter, the Z-depth of the tool needs to be held to $\pm .0015"$ which is not easy to do.

Even high quality countersink tools are notoriously unreliable on the dimension from their tip to X diameter along their cutting edge. This makes dialing in the tool more challenging the first time and after any tool replacement. Any additional time adds costs to the part. The higher tolerance that you need to hold the diameter to, the longer it will take to dial it in, and the more closely it will need to be watched while running the parts.

If the countersink is being used for a flathead screw, it might be possible to make the tolerance looser, possibly by removing a decimal place as shown in Figure 22. In this example, the countersink tolerance with one decimal place is $.5\text{mm}$ or approximately $\pm .020"$: a very generous and inexpensive tolerance. If you need to ensure the fastener head is not proud, then make the countersink a little deeper. To really ensure it is never proud, put that exact note on the drawing and specify the part number of the fastener that will be used. Having a "GO" gage is always a positive and quick way to check a feature.

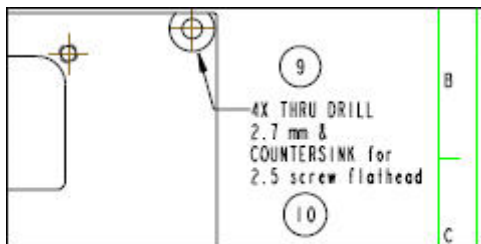

Fig. 22: Inexpensive countersink

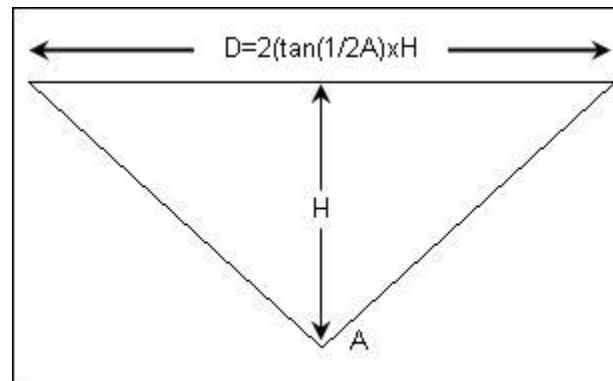

Fig. 21: Diameter vs. Depth relationship.

For machined chamfers that are not on holes, consider the use of the feature and tolerance it accordingly. Again, many engineers forget to loosen the tolerance and the shop is stuck dealing with a more challenging feature and overprocessing the manufacturing; ultimately, the customer is stuck paying for it.

Designing and Machining Plastic Parts

There are many applications where it makes sense to design a machined part to be made from plastic rather than metal. There are many types of plastic each with their unique strengths and applications. There are also some details that are good to know about how plastic responds to machining. Here are a few of the most common plastics we work with.

ABS comes in both natural (off white) and black and with various levels of glass fill. It is a relatively low-cost plastic that is easy to machine. It holds tolerances reasonably easily and sands and paints well. It has great impact strength and abrasion resistance. Be aware it is also hygroscopic which means it will absorb moisture from the air affecting dimensional stability. The tensile strength is approximately 6 KSI and it is generally available in round bar up to 4" diameter and plate up to 3" thick.

Acetal or (widely known by the brand name **Delrin**) is one of the best plastics to use for machined parts. It is a medium-cost plastic with good dimensional stability and excellent machinability. It has very low water absorption which improves dimensional stability. It is available in white, black, various levels of glass fill, or as Delrin AF which has Teflon fibers for increased wear characteristics. It has up to 10 KSI tensile strength and is generally available in round bar up to 6" diameter and plate up to 4" thick.

Acrylic is also known as PMMA. It is a low-cost plastic that has decent machining characteristics. With the right cutter geometry, very fine finishes can be achieved. It is a relatively hard and rigid plastic which makes it susceptible to chipping; avoid designing thin sections and sharp edges. Model radii and chamfers on outside edges to help reduce the chance of chipping. The main reason to design with acrylic is its excellent light transmission and optical properties. It has good impact strength but not as good as polycarbonate. It has better dimensional stability than many of the softer plastics although it is still susceptible to changing size with temperature fluctuations. It is also slightly hygroscopic but much less than most. Acrylic can be purchased in a MIL-P-5425 grade which is preshrunk to improve its dimensional stability. In our experience, if acrylic is to be painted after machining, then an additional annealing step is required to ensure it doesn't shrink further when the paint is cured. If threaded inserts are to be installed, it is advisable to rough-machine the material, install the inserts, anneal and then finish machine to reduce the chance of cracking induced by stress of the inserts being installed. Acrylic responds quite well to vapor polishing or flame polishing in applications where machining marks cannot be tolerated. It has about 9 KSI tensile strength and is available in round bar up to 6" diameter and plate up to 2" thick. (Shameless plug: Pro CNC is particularly good at turn-key acrylic parts!)

Nylon has a lot of great properties but comes with several disadvantages for machining. It is a low- (Nylon 6) to medium- (Nylon 6/6) cost plastic. It is pretty strong with tensile strength of about 11-12 KSI, but it is softer than acetal and much more hygroscopic. It tends to warp easily and it seems to move around when you machine it. It is terrible to deburr as it is very stringy and leaves behind fuzz unless cutters are razor sharp. It does have great toughness, wear, and abrasion resistance which is probably why it is harder to machine. Unless there is a specific property that is needed with Nylon, we generally advise acetal be used. There is also a grade of Nylon called MD or MDS. This grade has molybdenum disulfide in it which makes it more wear resistant than regular nylon and improves the machinability.

Polycarbonate has superior impact resistance. It is a medium-cost plastic. It comes in clear and black grades as well as myriad filled grades. It machines well, although like acrylic, can also be susceptible to chipping. It is a pretty stable material with very low water absorption and holds higher tolerances well. It has pretty good thermal resistance and resists deformation up to 265 degrees F. It also vapor polishes very well and can give excellent finishes. It has tensile strength of about 10 KSI and is available in round bar up to 6" and plate up to 2" thick.

Ultem is a translucent amber color and is a very high performance engineering thermoplastic. It is an expensive material but offers lots of great properties. It can handle very high temperatures: up to 340 degrees F. It is very stable dimensionally and has very low moisture absorption. It is also rigid but this rigidity contributes to the tendency to chip which is one of its drawbacks for machining. It is also slightly more abrasive than some plastics which increases tool costs. Ultem 1000 is the basic unfilled variety, with 2300 being the 30% glass version. It is extremely strong with about 17 KSI tensile strength and is available in round bar up to 4" and plate up to 2" thick.

Nearly all the materials above also come in more exotic flavors, such as carbon filled, stainless steel fiber filled, blends of different plastics, abrasion resistant, static-dissipative, tinted colors and even aramid fiber and glass bead

filled. There are also many other common machining grades of plastic such as UHMW, HDPE, and PVC. We will discuss these in future issues.

All plastics are less stable than metals. They have much higher thermal expansion and are affected by humidity if they are hygroscopic. These factors need to be taken in to account when designing and tolerancing your part.

It is not uncommon to have a machine shop machine and verify a part is in tolerance. A few weeks later, when the parts are inspected at the customer, the results are different, which may result in an out-of-tolerance condition. Care should be taken to reduce the chance of this happening. The best solution is to change the geometry to be more stable or increase the tolerance to allow natural variations to occur without becoming out of tolerance. Suggestions for improving the dimensional stability include designing thicker sections, adding ribs, allowing large fillets and adding corner radii. In contrast to injection molding recommendations, it isn't important to have the wall thicknesses be uniform and thin. Unless weight is a big factor, thick solid sections will be more stable and less costly to machine. The length to diameter recommendations for vertical cutting tools are similar to that for aluminum, if not a little less stringent.

In general we recommend allowing approximately +/- 0.001" of tolerance per inch of part size. There are some lower performance plastics that would need approximately double that much to be consistently easy to process and stay in tolerance. Because of the lower thermal (up to 10x greater than metal) and geometric stability of plastics it can be more costly to achieve higher tolerances. This is more true as parts get larger and sections get thinner. Sometimes the measurements themselves can cause deflection in the part which leads to erroneous readings. An example would be measuring a large ring with a caliper where the pressure from the caliper will elongate the ring causing it to appear out of tolerance. Non-contact measurement methods can be employed to reduce this problem.

If you are designing a round part that is a bearing, sleeve, or some type of part that will mate with a metal component, consider the application of an average diameter callout. It is common for round parts with thin wall thicknesses to ovalize which may not matter at all to the function of the part but may cause a big hassle for the part inspector. Alternatively, you can specify the type of fit you desire and provide a representative mating part for inspection.

As mentioned above many plastics are available with glass fill. This can add significant cost to the material itself as well as the machining cost; the glass fibers are very abrasive and tool wear becomes a significant factor. Depending on the amount of machining involved and tolerances required, some cutting tools may last less than one part, which adds considerable complexity to the manufacturing process. The higher the percentage of glass, the stronger, stiffer, and more dimensionally stable the parts will be. However, they will likewise be more expensive as well.

Threads and Plating

When a part has threaded holes and it is plated, there is always a potential to have problems with the thread class. All types of plating have a thickness. The plating thickness will vary greatly depending on the type of plating - from .0001" or less for Class 3 Chemical conversion coating, all the way up to .002" or more for Type III Hard Anodizing. The smaller the threads are, the higher a percentage of the pitch diameter tolerance will be used by up by the plating thickness. The same is true of high tolerance threads with a high thread class and a corresponding tighter pitch tolerance. The single biggest factor is the fact that the plating is applied to both sides of the thread profile on both

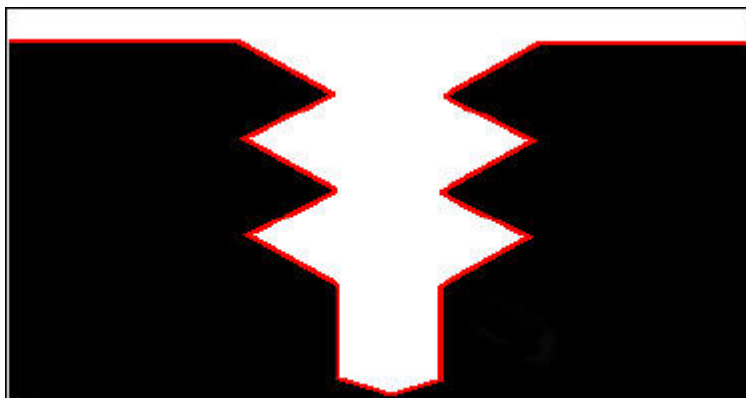

Fig. 23: 4x plating buildup on threaded holes.

sides of the hole. This translates into a 4x build up of plating on the threads. See Fig. 23. There are a two primary ways to negate this effect. One is to mask the hole during the plating process. This is the preferred method if the application does not require plating on the threads. The other method is to use an oversized tap during the machining process so that once the plating thickness is added onto the threads it still meets the thread class. Because plating thickness can vary, this method isn't 100% guaranteed to work, especially on smaller threads where the tolerance range is so small. If the resultant plating thickness doesn't match the oversize tap then you may still have the condition where the thread class is not in tolerance.

When masking holes, there is a chance of some of the chemicals bleeding into the hole. With proper masking techniques this should be minimal but it is still a potential and allowing a thread to be chased with a tap or cleaned out is advisable.

Blind holes present a few other problems to be aware of. Most types of plating require a good flow of chemicals over the surface metal to achieve good coverage and thickness. At the bottom of a blind hole, the chemicals do not have an opportunity to do this. This will often result in little or no plating at the bottom of the hole. There are two problems presented in this situation. One is that there will not be protection offered by the plating and the second is that if the thread was oversized in anticipation of the plating thickness, they the thread class might be out of spec on the large side of the tolerance. For plating types that are very thin, the issue of thickness may not be a factor at all, but the lack of coverage may be. Adding a note to the print that full coverage is not required at the bottom of the holes may head off potential problems.

Another common occurrence is that chemicals will be trapped in the bottom of the hole after the plating process is finished. Plating companies should blow out holes with compressed air to eliminate this problem but they do not always do it consistently. If you have blind holes from several sides, this is further exacerbated as you cannot rack the parts so that the plating solution can drain from the holes. With cosmetic plating types, such as colored anodize, often the chemicals can bleed out after the dyeing step of the process and cause runs to appear on the outer surface of the part, ruining the cosmetic nature of the finish. Another type of defect that can happen with blind threaded holes is that the chemicals that get trapped at the bottom actually dry out and then cause corrosion. We have seen this several times with chemical conversion coating. This underscores the importance of the plating company blowing out the holes.

As an engineer, you can try to avoid blind holes where possible, and allow masking of the holes during the plating process. By giving the option but not the requirement to do masking, you can leave that decision to the manufacturer and/or plater. Based on the configuration of the part, the type of plating, and orientation of the holes they can best make that decision. You can also specify a lower thread class or leave it out all together depending on the nature of your parts if you do require that plating be on the holes.

Raw Material Sizes

Earlier in the design guide, we discussed how costs can be saved by trying to minimize the size of raw material that is used in your design. What are the available sizes that one can design around? This answer certainly depends on what type of material you are using. It also depends on what your local material distributors happen to stock, or else you will be looking at getting something shipped in specifically for you which may not save money. Out here in the Pacific Northwest, in Boeing's backyard we are fortunate to have a very wide variety of aerospace grades of material available to us. It may vary around the country but we will discuss what is available around our area which hopefully is fairly representative of the country. We'll start with the materials we most often work with.

Aluminum

In the most common grade - 6061-T6 or -T6511 there are a wide variety of sizes available. In rectangular bar shapes, the thickness generally starts at 1/8" and goes in 1/8" increments up to 1.5" thick and then goes in 1/4" increments up to 6". The widths generally start at 1/2" wide and go in 1/4" increments up to 12" wide depending on the thickness. 2024 and 7075 alloys come in fewer sizes, and tend to follow 1/4" or 1/2" increments. Square bars are generally available in 1/4" increments with some smaller increments available under 1.5". The amount of material that is required to clean up a machined face is a consideration when trying to optimize the size of material that will be used. As we recommended in our December 2008 newsletter, it is advisable to leave 0.1" on the width dimension for square or rectangular bar stock unless you are expecting to leave the stock surfaces and tolerances in your finished part. On thickness, .125" is the minimum amount of extra material needed, primarily for work holding reasons. But the thicker the part, the more extra material is needed. On a part made from 4" or thicker bar, as much as .25" might be needed to hold on to the part. Consult your manufacturer to see what they suggest.

In aluminum round bar, a very wide variety of diameters are available. The sizes start at 1/8" diameter and go in 1/16" increments up to about 2", after which the increments are 1/8" up to about 5", and then 1/4" or 1/2" increments after that up to 20". The amount of excess stock that is needed to clean up is much smaller compared with rectangular shapes. But it varies considerably depending on the diameter of the material and the type of material (ie - extruded vs cold finished). As little as .020" can be anticipated to be cleaned up on the outer diameter for smaller diameter

PRO CNC INC	445 SEQUOIA DRIVE / SUITE 113 / BELLINGHAM / WA / 98226	
--------------------	---	---

materials. So if you were going to design a part to fit into 1.0" diameter bar stock, then try to make it no larger than .975" on the OD. This is a safe rule of thumb. There are cold finished grades of material which come with much tighter mill tolerances on the OD, allowing even closer dimensions to be achieved. Cold finished aluminum in a 1.0" diameter has a +/- .0025" tolerance, making it possible to design a .990" diameter part to be made from cold finished material. Extruded material on the other hand, has a much looser stock tolerance - +/- .012" on a 1.0" diameter, which is why it is prudent to leave at least .020" for clean up. The larger the material becomes, the looser the material tolerance, and you need to leave more room for clean up. 6" diameter extruded aluminum for example has a +/- .044" OD mill tolerance. So it would be advisable to leave at least .062" between the finished part diameter and the raw material. There are so many factors at play, the best option is to ask your manufacturer up front in the design phase so you can optimize the size needed.

Aluminum Plate

6061-T651 plate starts at .25" thick and with the exception of .3125", it comes in 1/8" increments up to 1.5" thick and then comes in 1/4" increments up to 3.5". After that, it is available in 1/2" increments up to about 8". With plate, similar to round bar, the thicker the size, the looser the mill tolerance will be and the more you should anticipate will need to be cleaned up. The thickness tolerance range is approximately .023" on 1/2" plate and .075" on 3" plate to give a rough idea.

Stainless Steel

There are such a wide variety of stainless steels, all of which seem to come in different sizes. The more common grades such as 303, 304, 316 and 416 come in nearly every size of round bar you can hope for. In rectangular sizes, the choices are more limited as some alloys come primarily in round and square sizes (for parts typically made on CNC turning centers). Tolerances on cold drawn round, square and rectangular bar are generally very good. Hot rolled variants have much lower tolerances and this needs to be accommodated for in your design.

Brass

Being a popular grade for turning, brass is available in very small increments up to about 6" round bar. The selections for square are decent, but your options are very limited for plate and as far as we know, rectangular sizes are not available at all. Mill tolerances are fairly good so not a lot of excess material is needed to ensure your part gets cleaned up from the raw material.

Steel

There are so many varieties and alloys of steel that it would be an enormous undertaking to describe them all. Similar to stainless steel, tolerances on round, square and rectangular bar are generally very good, especially in the cold drawn varieties. So allowance for material tolerance is not a big factor. Our recommendations for rectangular sizes of .1" on width and length and .125" on thickness would generally still apply. Recommendations on round parts are similar to those above for aluminum.

For all the materials we did cover there are far too many sizes available of all these materials to put in a chart for this newsletter, so we created a spreadsheet with all the most common sizes of material available. You can find the table [Raw Material Sizes](#) on our website. There are tabs at the bottom which allow you to specify which form of material you are looking at - round, square, rectangle, etc. Please bookmark this page and return often as you design your parts. If you would like to see additional materials included, please drop me an email to paul@procnc.com. This list may be missing some items, and may show some items that aren't always available but it is a good starting point for deciding what size material to use in your design. And please remember our advice about bar stock vs. plate! Bar stock generally costs about half that of cut plate - at least in aluminum. So if you can find a size that works for you, you'll save a lot of money right off the bat.